

RoHS

REV	DESCRIPTION	DATE

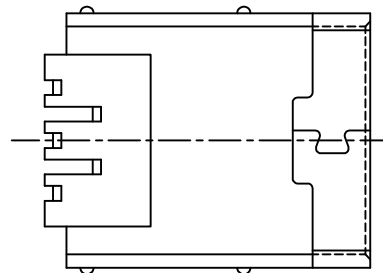
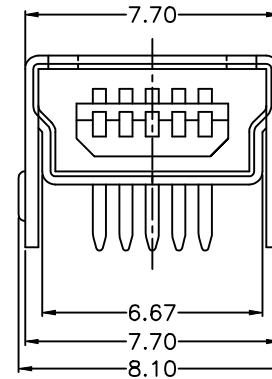
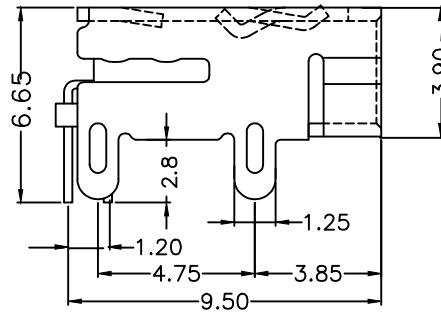
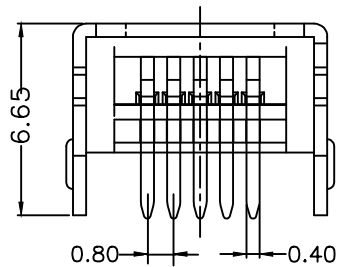
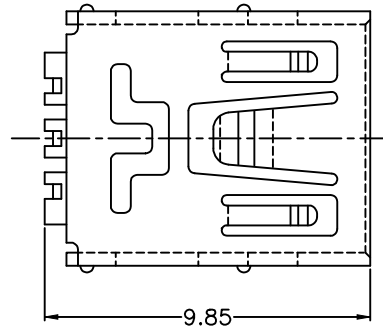

Specification:

- Electrical Characteristics:
 - Voltage Current rating: 1AMP. 30VAC
 - Insulation Resistance: 100MΩ min
 - Contact Resistance: 50mΩ max
- Environmental
 - Operating Temperature: -50°C to 85°C
- Material
 - Housing: LCP: Color: Black
 - Terminal: Phosphor bronze, T=0.25mm
 - Shell: Brass, T=0.4mm

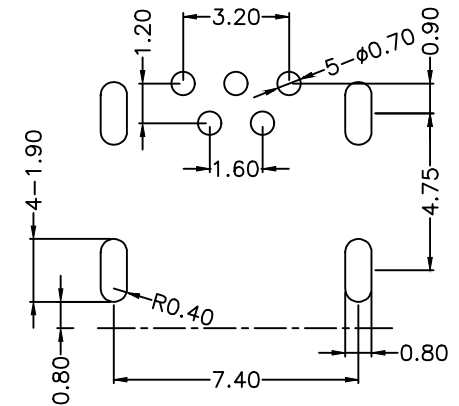

PCB LAYOUT

<p>CNT 肯耐特电子有限公司</p>			GENERAL TOLERANCE		DRAWN 董道丽	DATE 20191112	DWG. NO.	TITLE
			X.° ±5°	X. ±0.30	CHECK 王芳芳	DATE 20191112	PART. NO.	
REV. 1.0	UNIT mm	SCALE 1:1	.X° ±3°	.X ±0.38	APPROVE 王元中	DATE 20191112	CNT-USB-MINI-5P-TD	Mini-usb 5S B TYPE DIP (铜壳DIP四脚T形卡点)
			.XX° ±2°	.XX ±0.25				
			.XXX° ±1°	.XXX ±0.15				